

REQUEST FOR BIDS

BID NUMBER: 2013-13

THE EMERALD COAST UTILITIES AUTHORITY INVITES YOUR COMPANY TO SUBMIT A PROPOSAL ON ITEM (S) AS LISTED IN THIS BID REQUEST. IT IS THE INTENT OF THE EMERALD COAST UTILITIES AUTHORITY TO RECEIVE PROPOSALS THAT WILL BE PUBLICLY OPENED AT **2:00 P.M., AUGUST 15, 2013**, FOR THE FOLLOWING:

ITEM A – ANNUAL SERVICE CONTRACT FOR ENTRANCE ROADS
& TREES FOR LIFT STATION SITES

SEALED BIDS WILL BE RECEIVED UNTIL 2:00 P.M., AUGUST 15, 2013, BY THE PURCHASING AND STORES MANAGER, EMERALD COAST UTILITIES AUTHORITY, 9255 STURDEVANT STREET, ELLYSON INDUSTRIAL PARK, PENSACOLA, FLORIDA 32514. THE PROPOSALS RECEIVED WILL THEN BE PUBLICLY OPENED AND READ. THE EMERALD COAST UTILITIES AUTHORITY RESERVES THE RIGHT TO WAIVE INFORMALITIES IN ANY BID; REJECT ANY OR ALL PROPOSALS, IN WHOLE OR IN PART; RE-BID A PROJECT, IN WHOLE OR IN PART; AND TO ACCEPT A PROPOSAL THAT IN ITS JUDGEMENT IS THE LOWEST AND BEST BID OF A RESPONSIBLE BIDDER. IN ACCEPTING A BID, ECUA MAY AWARD A CONTRACT BASED ONLY ON THE BASE BID, THE BASE BID PLUS ALL ALTERNATES, OR THE BASE BID PLUS ANY ALTERNATES WHICH ECUA SELECTS – WITH ALL DECISIONS BEING MADE BASED UPON WHAT ECUA BELIEVES TO BE THE BEST INTERESTS OF ITS RATEPAYERS, IN THE REASONABLE EXERCISE OF ITS DISCRETION. ECUA FURTHER RESERVES THE RIGHT TO INCREASE OR DECREASE QUANTITIES AS MAY BE REQUIRED TO MEET THE NEEDS OF ECUA, AT THE UNIT PRICE WHICH WAS BID.

LEGAL ADVERTISEMENT

Sealed bids for Bid #2013-13, Annual Service Contract for Entrance Roads & Trees for Lift Station Sites, will be received by the Emerald Coast Utilities Authority Purchasing & Stores Manager, 9255 Sturdevant Street, Ellyson Industrial Park, Pensacola, FL 32514, until 2:00 p.m., August 15, 2013, at which time bids submitted will be publicly opened and read. Specifications and information may be examined and obtained from the ECUA website at www.ecua.fl.gov/business/bid-opportunities, or from the ECUA Purchasing & Stores Manager at 850-969-3350. Bids received after the closing time will be returned unopened. ECUA reserves the right to reject any or all bids and re-advertise.

Advertised 07/18/13

**Emerald Coast Utilities Authority
Purchasing and Stores Division
9255 Sturdevant Street
Pensacola, Florida 32514-7038
850-969-3350**

STATEMENT OF NO BID

If you **do not** intend to bid on this commodity/service, please return this form to the above address immediately. If this statement is not completed and returned, your company may be deleted from the Emerald Coast Utilities Authority Vendors' list for this commodity/service.

We the undersigned have declined to bid on requested commodity/service Bid #2013-13, Annual Service Contract for Entrance Roads & Trees for Lift Station Sites, for the following reasons:

- Specifications too "tight," i.e. geared toward one brand or manufacturer only (explain below).
- Insufficient time to respond to the Invitation to Bid.
- We do not offer this product or service.
- Our schedule would not permit us to perform.
- Unable to meet bond/insurance requirements.
- Specifications are unclear (explain below).
- Remove us from your vendors' list for this commodity/service.
- Other (specify below).

Remarks:

Company Name: _____

Signature: _____

Telephone: _____ Date: _____

NOTE: Statement of No Bid may be faxed into the Purchasing and Stores Division, (850-969-3384) Attention: Amy Williamson

INSTRUCTIONS TO BIDDERS

ALL THESE TERMS AND CONDITIONS ARE A PART OF THIS BID REQUEST.

1. BID SCHEDULE:

BIDS ARE PRESENTLY SCHEDULED TO BE PUBLICLY OPENED AND READ AT 2:00 P.M., AUGUST 15, 2013 IN THE ECUA PURCHASING SECTION, 2ND FLOOR, EMERGENCY OPERATIONS SUPPORT ADDITION, 9255 STURDEVANT STREET, ELLYSON INDUSTRIAL PARK. ECUA STAFF WILL REVIEW ALL BIDS AND FORWARD THEIR RECOMMENDATIONS TO THE CITIZENS ADVISORY COMMITTEE AT THEIR MEETING SCHEDULED FOR SEPTEMBER 18, 2013, IN THE ECUA BOARD ROOM AT 9255 STURDEVANT STREET, ELLYSON INDUSTRIAL PARK, PENSACOLA, FL 32514, AND THEN ON TO THE ECUA BOARD AT THEIR MEETING SCHEDULED FOR 3:00 P.M., SEPTEMBER 26, 2013, AT THE SAME LOCATION.

2. BID SUBMISSION:

ONE ORIGINAL AND FOUR COPIES OF ALL BIDS TO BE CONSIDERED MUST BE IN THE POSSESSION OF THE EMERALD COAST UTILITIES AUTHORITY PURCHASING AND STORES MANAGER. BIDS MAY BE MAILED OR DELIVERED TO HIS OFFICE AT 9255 STURDEVANT STREET, ELLYSON INDUSTRIAL PARK, PENSACOLA, FLORIDA, 32514, IN A SEALED ENVELOPE CLEARLY MARKED WITH THE TIME AND DATE OF THE OPENING. REGARDLESS OF THE METHOD OF DELIVERY, EACH BIDDER SHALL BE RESPONSIBLE FOR HIS BID(S) BEING DELIVERED ON TIME, AS THE EMERALD COAST UTILITIES AUTHORITY ASSUMES NO RESPONSIBILITY FOR SAME. PROPOSALS OFFERED OR RECEIVED AFTER THE TIME SET FOR THE BID OPENING WILL BE REJECTED AND RETURNED UNOPENED TO THE BIDDER.

3. CONVICTION OF PUBLIC ENTITY CRIME

A PERSON OR AFFILIATE WHO HAS BEEN PLACED ON THE CONVICTED VENDOR LIST FOLLOWING A CONVICTION FOR A PUBLIC ENTITY CRIME MAY NOT SUBMIT A BID ON A CONTRACT TO PROVIDE ANY GOODS OR SERVICES TO A PUBLIC ENTITY, MAY NOT SUBMIT A BID ON A CONTRACT WITH A PUBLIC ENTITY FOR THE CONSTRUCTION OR REPAIR OF A PUBLIC BUILDING OR PUBLIC WORK, MAY NOT SUBMIT BIDS ON LEASES OF REAL PROPERTY TO A PUBLIC ENTITY, MAY NOT BE AWARDED OR PERFORM WORK AS A CONTRACTOR, SUPPLIER, SUBCONTRACTOR, OR CONSULTANT UNDER A CONTRACT WITH ANY PUBLIC ENTITY, AND MAY NOT TRANSACT BUSINESS WITH ANY PUBLIC ENTITY IN EXCESS OF THE THRESHOLD AMOUNT PROVIDED IN SECTION 287.017, FOR CATEGORY TWO (\$35,000) FOR A PERIOD OF 36 MONTHS FROM THE DATE OF BEING PLACED ON THE CONVICTED VENDOR LIST.

4. BID WITHDRAWAL:

NO BID MAY BE WITHDRAWN FOR A PERIOD OF NINETY (90) DAYS FROM THE BID OPENING. PRICES MAY NOT BE MODIFIED DURING THIS PERIOD. PROPOSALS MAY BE WITHDRAWN AT ANY TIME PRIOR TO THE BID OPENING TIME.

5. BID AUTHORIZATION:

ALL BIDS MUST BE SUBMITTED ON THE FORM PROVIDED BY THE EMERALD COAST UTILITIES AUTHORITY AND MUST BE SIGNED BY AN AUTHORIZED REPRESENTATIVE OF THE COMPANY PLACING THE BID. ONE COMPLETE SET OF BID FORMS WILL BE FURNISHED EACH COMPANY INTERESTED IN BIDDING.

6. BID ERRORS:

A BIDDER MAY NOT MODIFY ITS BID AFTER BID OPENING. ERRORS IN THE EXTENSION OF UNIT PRICES STATED IN A BID OR IN MULTIPLICATION, DIVISION, ADDITION, OR SUBTRACTION IN A BID MAY BE CORRECTED BY THE PURCHASING AND STORES MANAGER PRIOR TO AWARD. IN SUCH CASES, UNIT PRICES SHALL NOT BE CHANGED.

7. AWARD OF BID:

ECUA RESERVES THE RIGHT TO ESTABLISH PRIORITIES AND TO AWARD THE CONTRACT TO A SINGLE BIDDER BASED UPON THE TOTAL BID OR TO MULTIPLE VENDORS BASED UPON THE ITEMS INDIVIDUALLY BID. ECUA ALSO RESERVES THE RIGHT TO SELECTIVELY PURCHASE ANY SINGLE OR ANY MULTIPLE ITEMS FROM THIS BID.

8. TAXES:

DO NOT INCLUDE ANY TAX WITH YOUR BID. THE EMERALD COAST UTILITIES AUTHORITY IS EXEMPT FROM FEDERAL, STATE AND LOCAL TAXES. TAX EXEMPT NUMBER 85-8012640152C-4 APPLIES.

9. TERMS:

MINIMUM TERMS WILL BE NET 30 (30 DAYS AFTER RECEIPT OF MATERIAL/SERVICE) UNLESS A DISCOUNT IS INVOLVED. TERMS OFFERING A DISCOUNT FOR PROMPT PAYMENT WILL ONLY BE CONSIDERED IN DETERMINING THE LOW BID IF THE DISCOUNT PERIOD IS 15 DAYS OR GREATER (15 DAYS AFTER RECEIPT OF MATERIAL/SERVICE OR INVOICE, WHICHEVER IS GREATER).

10. BID TABULATIONS:

BID TABULATIONS WILL BE POSTED FOR REVIEW IN THE PURCHASE SECTION, 9255 STURDEVANT STREET, ELLYSON INDUSTRIAL PARK ON OR ABOUT AUGUST 15, 2013, AND WILL REMAIN POSTED FOR 72 HOURS EXCLUDING WEEKENDS AND HOLIDAYS.

11. BID QUESTIONS:

IF ANY BIDDER HAS A QUESTION CONCERNING THE BID SPECIFICATIONS OR BID PROCEDURES, PLEASE FORWARD THE INQUIRY TO THE PURCHASING AND STORES MANAGER BEFORE AUGUST 8, 2013, FOR CONSIDERATION.

EMERALD COAST UTILITIES AUTHORITY
ATTN: PURCHASING AND STORES MANAGER
9255 STURDEVANT STREET
PENSACOLA, FLORIDA 32514-7038
PHONE: 850-969-6531
FAX: 850-969-3384
EMAIL: amy.williamson@ecua.fl.gov

12. COMPLIANCE WITH SPECIFICATIONS:

IN ORDER TO DETERMINE THAT YOUR BID COMPLIES WITH BID SPECIFICATIONS, PRODUCT LITERATURE AND/OR DATA/INFORMATION SHOULD BE INCLUDED WITH THE BID PROPOSAL. ANY DEVIATIONS FROM THE BID SPECIFICATIONS SHOULD BE IDENTIFIED SEPARATELY.

13. UNIFORM COMMERCIAL CODE:

THE UNIFORM COMMERCIAL CODE (FLORIDA STATUTES, CHAPTER 672) SHALL PREVAIL AS THE BASIS FOR CONTRACTUAL OBLIGATIONS BETWEEN THE AWARDED VENDOR/CONTRACTOR AND EMERALD COAST UTILITIES AUTHORITY FOR ANY TERMS AND CONDITIONS NOT SPECIFICALLY STATED IN THIS INVITATION FOR BID.

14. EXECUTION OF CONTRACT:

ANY ACTION OF ECUA IN AWARDING THE PURCHASE OF ANY MATERIAL OR PERFORMANCE OF A SERVICE IS SUBJECT TO AND CONDITIONED UPON THE EXECUTION OF A WRITTEN PURCHASE CONTRACT AND/OR A PURCHASE ORDER BETWEEN ECUA AND THE VENDOR.

15. CONTRACTUAL AGREEMENT:

THIS INVITATION FOR BID SHALL BE INCLUDED AND INCORPORATED IN THE FINAL CONTRACT OR PURCHASE ORDER. THE ORDER OF CONTRACT PRECEDENCE WILL BE THE CONTRACT (PURCHASE ORDER), BID DOCUMENT AND RESPONSE. ANY AND ALL LEGAL ACTION NECESSARY TO ENFORCE THE CONTRACT WILL BE HELD IN ESCAMBIA COUNTY AND THE CONTRACT WILL BE INTERPRETED ACCORDING TO THE LAWS OF FLORIDA.

16. PROTESTS:

ANY PERSON WHOSE SUBSTANTIAL INTERESTS ARE DIRECTLY AND ADVERSELY AFFECTED BY THE AWARD OR INTENDED AWARD OF A PURCHASE ORDER OR CONTRACT OR BY PLANS OR SPECIFICATIONS CONTAINED IN AN INVITATION TO BID OR REQUEST FOR PROPOSALS MAY FILE A PROTEST IN ACCORDANCE WITH THE FOLLOWING RULES AND SECTION 12 OF THE ECUA ACT (CHAPTER 2001-324, LAWS OF FLORIDA AS AMENDED).

NOTICE OF PROTEST OF PLANS, SPECIFICATIONS OR OTHER REQUIREMENTS CONTAINED IN AN INVITATION TO BID OR IN A REQUEST FOR PROPOSALS SHALL BE FILED NOT LATER THAN 5:00 P.M. OF THE THIRD BUSINESS DAY FOLLOWING RECEIPT OF THE PLANS OR SPECIFICATIONS. NOTICE OF PROTEST OF THE REJECTION OF A BID OR PROPOSAL AS NON-RESPONSIVE SHALL BE FILED NOT LATER THAN 5:00 P.M. OF THE THIRD BUSINESS DAY FOLLOWING NOTICE TO THE BIDDER OF THE REJECTION. NOTICE OF PROTEST OF THE AWARD OR INTENDED AWARD OF A PURCHASE ORDER OR CONTRACT TO THE LOWEST BIDDER SHOWN ON A POSTED BID TABULATION SHALL BE FILED NOT LATER THAN 5:00 P.M. OF THE THIRD BUSINESS DAY FOLLOWING THE POSTING OF THE BID TABULATION. NOTICE OF PROTEST OF THE AWARD OR INTENDED AWARD OF A PURCHASE ORDER OR CONTRACT TO A BIDDER OTHER THAN THE LOWEST BIDDER SHOWN ON A POSTED BID TABULATION SHALL BE FILED NOT LATER THAN 5:00 P.M. OF THE THIRD BUSINESS DAY FOLLOWING NOTICE OF THE AWARD OF A PURCHASE ORDER OR CONTRACT.

A NOTICE OF PROTEST SHALL BE IN WRITING AND SHALL STATE THE SUBJECT MATTER OF THE PROTEST.

A FORMAL WRITTEN PROTEST SHALL BE FILED WITHIN SEVEN (7) BUSINESS DAYS AFTER THE FILING OF NOTICE OF PROTEST. A FORMAL WRITTEN PROTEST SHALL STATE WITH PARTICULARITY THE FACTS AND THE LAW ON WHICH THE PROTEST IS BASED.

NOTICE OF PROTEST AND FORMAL WRITTEN PROTEST OF PLANS OR SPECIFICATIONS FOR OR THE AWARD OR INTENDED AWARD OF A CONTRACT SHALL BE FILED WITH THE EXECUTIVE DIRECTOR OR HIS OR HER DESIGNEE.

FAILURE TO FILE A NOTICE OF PROTEST OR FAILURE TO FILE A FORMAL WRITTEN PROTEST WITHIN THE TIMES PERMITTED SHALL CONSTITUTE A WAIVER OF PROCEEDINGS UNDER THESE RULES AND UNDER SECTION 12 OF CHAPTER 2001-324, LAWS OF FLORIDA, AS AMENDED.

UPON RECEIPT OF A NOTICE OF PROTEST WHICH HAS BEEN TIMELY FILED, THE EXECUTIVE DIRECTOR SHALL STOP THE BID SOLICITATION OR PURCHASE ORDER OR CONTRACT AWARD PROCESS UNTIL THE PROTEST HAS BEEN RESOLVED. HOWEVER, THE BID SOLICITATION OR PURCHASE ORDER OR CONTRACT AWARD PROCESS MAY PROCEED WHEN THE EXECUTIVE DIRECTOR DETERMINES THAT DELAY WOULD BE DETRIMENTAL TO THE INTERESTS OF ECUA. ANY AWARD OF A PURCHASE ORDER OR CONTRACT UNDER SUCH CONDITIONS SHALL BE SUBJECT TO THE OUTCOME OF THE PROTEST. AFTER THE AWARD OF A CONTRACT OR PURCHASE ORDER RESULTING FROM A BID IN WHICH A TIMELY PROTEST WAS RECEIVED AND IN WHICH ECUA DID NOT PREVAIL, ECUA MAY TAKE SUCH ACTION AS IT CONSIDERS APPROPRIATE, WHICH MAY INCLUDE, BUT SHALL NOT BE LIMITED TO, AWARD OF THE CONTRACT OR PURCHASE ORDER TO THE PREVAILING PARTY, CANCELLATION OF THE CONTRACT OR PURCHASE ORDER, OR REBIDDING.

THE EXECUTIVE DIRECTOR SHALL PROVIDE REASONABLE OPPORTUNITY TO RESOLVE A PROTEST BY AGREEMENT. IF AGREEMENT IS NOT REACHED WITHIN SUCH TIME AS THE EXECUTIVE DIRECTOR OR HIS OR HER DESIGNEE CONSIDERS REASONABLE UNDER THE CIRCUMSTANCES, THE EXECUTIVE DIRECTOR OR HIS OR HER DESIGNEE SHALL REVIEW THE FACTS AND THE LAW ON WHICH THE PROTEST IS BASED, AND SHALL RENDER A DECISION WHICH SHALL BE IN WRITING AND SHALL BE PROMPTLY TRANSMITTED TO THE PROTESTOR.

IF THE PROTESTOR WISHES TO CONTINUE THE PROTEST BEYOND THE DECISION OF THE EXECUTIVE DIRECTOR OR HIS OR HER DESIGNEE, THE PROTESTOR SHALL BE REQUIRED TO FILE A PETITION FOR REVIEW BY THE ECUA BOARD. THIS PETITION SHALL BE MADE IN WRITING AND PRESENTED TO THE EXECUTIVE DIRECTOR WITHIN TEN (10) DAYS AFTER NOTICE OF THE DECISION OF THE EXECUTIVE DIRECTOR OR HIS OR HER DESIGNEE; OTHERWISE, THE DECISION OF THE EXECUTIVE DIRECTOR OR HIS OR HER DESIGNEE SHALL BE FINAL AND BINDING. SUCH PETITION SHALL STATE THE PARTICULAR GROUNDS ON WHICH IT IS BASED AND MAY INCLUDE PERTINENT DOCUMENTS AND EVIDENCE RELATING THERETO. ANY GROUNDS NOT STATED SHALL BE DEEMED TO HAVE BEEN WAIVED BY THE PROTESTOR. THIS PETITION MUST ALSO BE ACCOMPANIED BY A PROTEST BOND OF AN AMOUNT EQUAL TO 1.0 PERCENT (1%) OF THE VALUE OF THE SOLICITATION, BUT IN NO CASE LESS THAN \$1,000 NOR GREATER THAN \$10,000.00. THIS BOND SHALL BE IN THE FORM OF A MONEY ORDER, CERTIFIED CASHIER'S CHECK, OR CERTIFIED BANK CHECK MADE PAYABLE TO THE EMERALD COAST UTILITIES AUTHORITY. FAILURE TO POST SUCH BOND WITHIN TEN (10) BUSINESS DAYS AFTER THE DECISION OF THE EXECUTIVE DIRECTOR OR HIS OR HER DESIGNEE SHALL RESULT IN THE PROTEST BEING DISMISSED BY THE EXECUTIVE DIRECTOR.

THE BOND REQUIRED BY THE ABOVE PARAGRAPH SHALL BE CONDITIONED UPON THE PAYMENT OF ALL COSTS AND CHARGES WHICH MAY BE ADJUDGED AGAINST THE PERSON FILING THE PETITION FOR REVIEW. IF THE PROTESTOR PREVAILS, THE BOND SHALL BE RETURNED TO THE PROTESTOR. IF HOWEVER, ECUA PREVAILS, THE BOND SHALL BE FORFEITED, AND ECUA SHALL BE ENTITLED TO RECOVER THE COSTS AND CHARGES, EXCLUDING ATTORNEY'S FEES, OF SUCH HEARING. THE ENTIRE AMOUNT OF THE BOND ALSO SHALL BE FORFEITED IF IT IS DETERMINED THAT A PROTEST WAS FILED FOR A FRIVOLOUS OR IMPROPER PURPOSE, INCLUDING, BUT NOT LIMITED TO, THE PURPOSE OF HARASSING, CAUSING UNNECESSARY DELAY, OR CAUSING NEEDLESS COST FOR ECUA OR ANOTHER INTERESTED PARTY/PARTIES.

ANY NOTICE REQUIRED OR PERMITTED UNDER THIS BID PROTEST PROCEDURE SHALL BE EFFECTIVE WHEN DELIVERED PERSONALLY OR BY FACSIMILE, OR WHEN DEPOSITED IN THE U.S. MAIL. IF NOTICE IS GIVEN ONLY BY MAIL, THREE (3) DAYS SHALL BE ADDED TO THE TIME WITHIN WHICH A PROTESTOR MAY FILE A NOTICE OF PROTEST OR PETITION FOR REVIEW.

17. CONTRACTS EXCEEDING ONE YEAR:

WHEN APPLICABLE, A CONTRACT MAY BE RENEWED CONTINGENT UPON COST FACTORS, MUTUAL AGREEMENT, SATISFACTORY PERFORMANCE EVALUATIONS, AVAILABILITY OF FUNDS AND ECUA BOARD APPROVAL. ECUA'S PERFORMANCE AND OBLIGATION TO PAY FOR THE PURCHASE OF SERVICES OR TANGIBLE PERSONAL PROPERTY OF A PERIOD IN EXCESS OF ONE (1) FISCAL YEAR UNDER ANY CONTRACTUAL RELATIONSHIP IS CONTINGENT UPON AN ANNUAL BUDGET APPROVAL BY THE ECUA BOARD.

EMERALD COAST UTILITIES AUTHORITY

BID NUMBER: 2013-13

SPECIFICATIONS

ANNUAL SERVICE CONTRACT FOR ENTRANCE ROADS & TREES FOR LIFT STATION SITES

Contract Effective: September 1, 2013 through August 31, 2014 (With two one-year optional extensions upon mutual agreement of both parties, with no increase in price).

General Description of Work:

Clearing, grubbing and repair of existing driveways, construction of entrance roads servicing ECUA lift stations/pumping stations.

- A. This contract will include the installation/compaction of all road base materials and preparatory work. Prior to installation, roadway aggregates must be approved by ECUA per project. These aggregates can include crushed concrete, lime rock, Bahama base and asphalt millings as approved by ECUA per project. Vendors approved for purchasing these materials will include Martin Marietta and Vulcan. Crushed concrete and asphalt milling will have to be approved before purchase.
- B. All site work, material and construction methods shall be in accordance with ECUA, FDEP, and the latest FDOT standards unless otherwise noted. In the event of a conflict, the contractor shall coordinate with ECUA and ECUA standards shall prevail.
- C. Clearing and grubbing shall include all trees, stumps, brush, roots, vegetation, logs and trash included within scope of each project determined by ECUA.
- D. Clearing and grubbing shall be in advance of removing unsuitable materials and adding suitable base before the installation of road aggregate. Contractor to utilize ECUA container services. (476-5110 Ext. 6610)
- E. Disposal and haul off shall be in accordance with all applicable federal, state and local regulating agencies of all unsalvageable material and yard waste to an ECUA approved dump site shall be the responsibility of the contractor. Burning is prohibited. Contractor shall provide manifests for proof of proper disposal prior to processing any invoices.
- F. Thickness of base and road aggregate will be specified by ECUA as dictated by conditions at each project site. (See attached driveway detail sheet)
- G. Contractor is responsible for the protection of all structures, equipment and utilities. The location and spotting of all utilities will be done in advance by the contractor to protect all utilities and ECUA property as well as private property. The contractor shall clearly stake the site and boundaries of the work based on the survey provided by ECUA.
- H. Access into the ECUA station will be maintained at all times. When access to the site is not available, different means will be coordinated between ECUA and the contractor.
- I. Dewatering and surface water encounters will be handled by and the sole responsibility of the contractor. Dewatering will be handled only by ECUA, Escambia County and FDEP approved methods.
- J. Changes in grade must be approved by ECUA.

- K. All construction activities for this project shall incorporate the best method to control erosion, sedimentation and the potential for downstream water quality degradation by the contractor. Erosion practices will include turbidity barriers, hay bales and silt fencing as approved by and set to FDEP and ECUA's standards.
- L. Stabilization of earth will be done and approved by ECUA. Sod, hay and seed will be performed after entrance road or repairs are completed.
- M. Contractor must have the equipment readily available to properly excavate, grade and install the driveway or entrance road and associated site work.
- N. On an emergency project, Contractor must be able to respond within 4 hours of notice and achieve full mobilization within 6 hours. Contractor shall have enough materials on hand to handle an emergency repair.
- O. Upon notification of a routine project, the contractor must be able to mobilize within 48 hours and begin rebuilding and maintaining of the ECUA site and roadway. Contractor must provide access to the site for ECUA trucks and personnel in order to allow ECUA to continue to maintain their equipment. All work shall be completed in a timely manner.
- P. Upon commencement of the project, contractor will make the rebuilding or repairs their top priority. While working on ECUA property, the contractor must display a professional demeanor to not only ECUA but also to the property of its neighbors as well.
- Q. All required permitting and utility spots/ locates will be obtained prior to the start of the project and are the sole responsibility of the contractor.
- R. Contractors will be required to have a valid State of Florida General Contractor's License with 5 years of experience in performing this type of earth work or possess a valid Florida Certified Underground Utility and Excavation Contractor License.

Scope of Work:

Tree & Vegetation Removal at ECUA Lift Stations

- A. Scope of work will include the following: tree removal, tree trimming, stump grinding, bush hogging and any service related to the maintaining and care of trees and vegetation at ECUA lift stations. Description of work will cover general tree and vegetation maintenance, emergency tree maintenance, disposal of all associated debris. Disposal and haul off shall be in accordance with all applicable federal, state and local regulating agencies for all yard waste and to an ECUA approved dump site shall be the responsibility of the contractor. Burning is prohibited. Contractor shall provide manifests for proof of proper disposal prior to processing any invoices.

A typical project would include:

- Tree trimming
- Vegetation removal
- Tree removal
- Stump grinding
- Storm and emergency tree work
- Dangerous tree removal; removal of trees and limbs around power lines, fences and operating equipment
- Bucket truck and skid steer services

Equipment required will include:

- 40' bucket truck
- Tractor and bush hog
- Stump grinder
- Truck/trailer/container for tree and vegetation removal
- Skid steer

Contractor must have all equipment readily available to mobilize when required.

Tree and vegetation work will fall into two categories:

- Emergency – this type of job will require contractor to respond within 4 hours of notice with mobilization and begin work within 6 hours.
- Scheduled – this work will be arranged and completed within 7 calendar days.

Contractor will be responsible for:

- All required permitting.
- Locating and spotting all utilities prior to commencement of work.
- The protection of all structures, equipment and utilities on site.
- Disposal of debris to an approved dump site will be the responsibility of the contractor. Proof of proper disposal is required with the invoice.
- The stabilization of earth after tree removal.

Access into the ECUA property will be maintained at all times when work is performed. Continued service of the lift stations must be of the highest priority.

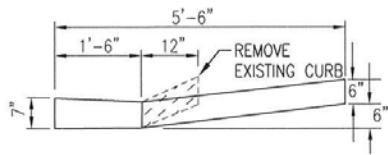

SECTION A-A
NOT TO SCALE

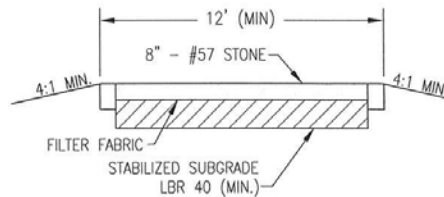

SECTION B-B
NOT TO SCALE

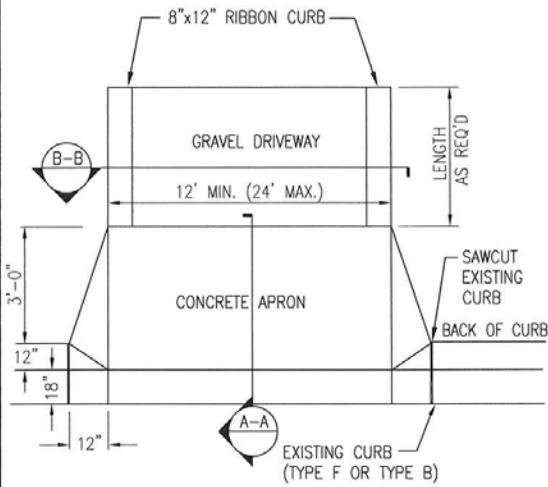

DRIVEWAY APRON
NOT TO SCALE

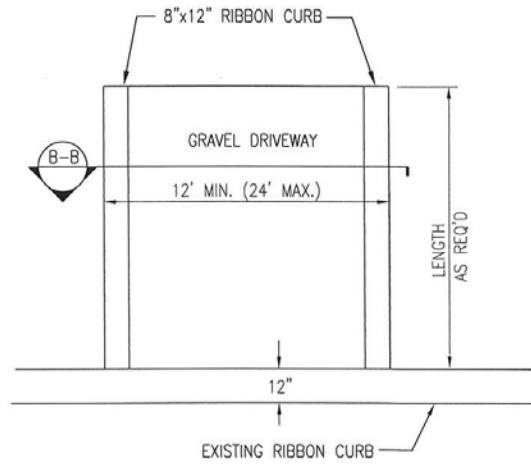

DRIVEWAY W/O APRON
NOT TO SCALE

- NOTES:
1. 3000 PSI CONCRETE (CLASS B)
 2. 1/2" DEEP DUMMY JOINTS 6' ON CENTER
 3. EXPANSION JOINTS 30' ON CENTER
 4. EDGED WITH 1/2" RADIUS AND BROOM FINISH
 5. 6/6 W.W.M. - 10 GAUGE
 6. ALL SLOPES SHALL BE NEATLY DRESSED TO TRUE LINE AND GRADE

K:\27941\27941.05 - Bayou Marcus\DWG\Driveway Detail.dwg, May 13, 2013 - 8:11:31AM, lortenton

| | | | |
|------------------------------------------------------------------------------------------------------------------------------------------------------------------------------------------------------------------------------------------------------------------------------------------------------------------------------------------------------------------------------------------------------------------------------------------------------------------------------|-------------------------------|-----------------------|---------------|
| BASKERVILLE-DONOVAN, INC. Innovative Infrastructure Solutions 449 W. MAIN ST., PENSACOLA, FL 32502 (850)438-9661 ENGINEERING BUSINESS: EB-0000340 <small>Pensacola - Panama City Beach - Tallahassee - Mobile - Gwynedd County - Tampa</small> <small>This drawing is the property of BASKERVILLE-DONOVAN, INC. and is not to be reproduced in whole or in part, it is not to be used on any other project and is to be returned upon request.</small> | Project: ECUA DRIVEWAY DETAIL | Sheet 1 | |
| | Project No.: 27941.03 | | Date: 04/2013 |
| | Scale: NONE | | By: THO |

| Item | Description | Unit | Unit Price | Extension |
|-------------|-----------------------------------------------|-------------|-------------------|------------------|
| 1 | Project manager (regular hours) | HR | | |
| 2 | Supervisor (regular hours) | HR | | |
| 3 | Operator (regular hours) | HR | | |
| 4 | Laborer (regular hours) | HR | | |
| 5 | Project Manager (overtime hours) | HR | | |
| 6 | Supervisor (overtime hours) | HR | | |
| 7 | Operator (overtime hours) | HR | | |
| 8 | Laborer (overtime hours) | HR | | |
| 9 | Supervisor pick-up truck (incl typical tools) | HR | | |
| 10 | Crew truck (incl. typical tools) | HR | | |
| 11 | 40' bucket truck | HR | | |
| 12 | Mobilization/demobilization | EA | | |
| 13 | Full size excavator | HR | | |
| 14 | Backhoe/mini excavator | HR | | |
| 15 | Tractor and bush hog | HR | | |
| 16 | Stump grinder | HR | | |
| 17 | Trailer | HR | | |
| 18 | Debris Disposal container | HR | | |
| 19 | Skid steer | HR | | |
| 20 | Plate compactor | HR | | |
| 21 | Bahama rock road base materials | CY | | |
| 22 | Crushed concrete road base materials | CY | | |
| 23 | Asphalt milling road base materials | CY | | |
| 24 | Lime Rock road base materials | CY | | |
| 25 | Silt fencing | EA | | |
| 26 | Sod, hay, seeding | EA | | |
| 27 | Rebar | FT | | |
| 28 | Culvert pipe | EA | | |
| | | | | |
| | | | | |
| | | | | |
| | | | | |
| | | | | |
| | | | | |
| | | | | |
| | | | | |

Items 1 - 4 (Regular labor rates): Labor rates include all direct and indirect costs, including overhead costs associated with employees. Work crews shall be properly staffed with the correct proportion of supervisors, operators, and laborers. Crew size should be kept as small as possible while still being able to competently and efficiently perform the task. Project Manager time is limited to field meetings, time spent with crews on job site and maximum 4 hours per task preparing various paperwork (additional time involved should be captured in overhead costs). ECUA inspector or field representative will monitor labor hours. Contractor shall keep daily hourly logs for inspection if requested.

Items 5 – 8 (Overtime labor rates): Overtime labor rates should include normal rates plus markup for direct overtime labor costs (i.e. additional percentage applied to direct labor costs only, not applied to overhead costs). ECUA will advise contractor of when overtime rates will apply (i.e. ECUA requested work on weekends or nights or over 40 hours per week on ECUA tree, vegetation and driveway work). Overtime rates are generally not required for tree, vegetation and driveway work. ECUA inspector or field representative will monitor labor hours. Contractor shall keep daily hourly logs for inspection if requested.

Items 9 – 11 (Work trucks): Vehicle rates include gas, maintenance, and shall include tools required to perform various water and sewer related work, to include but not limited to chain saw, hand saw, small generators, and pipe cutters, etc.

Items 12 (Mobilization/Demobilization): Includes the labor and vehicles required for delivery and removal of all equipment.

Items 13 – 14 (Equipment): Item 13 shall be capable of performing work in small work spaces (payment shall be based on actual time used, no payment for periods of non-use on project site).

Items 15 – 20 (Misc. equipment): Miscellaneous equipment items include gas, maintenance, blades, power supply (generator, compressor, and batteries), etc. Payment shall be based on actual time used, no payment for periods of non-use on project site.

Items 21 (Road base materials): Can include crushed concrete, lime rock, Bahama base and asphalt millings as approved by ECUA per project. Vendors approved for purchasing these materials will include Martin Marietta and Vulcan. Crushed concrete and asphalt milling will have to be approved before purchase. Thickness of base and road aggregate will be specified by ECUA as dictated by conditions at each project site.

Items 22 – 27 (Misc. materials): Payment will be based on actual invoice amount plus 10% mark-up. Invoices for materials must be supplied with bill for completed project.

Notes:

Overhead and other related costs: Contractor shall perform mobilization of all equipment used in this contract, erosion control, and traffic control, with all forms of overhead built into unit prices. Contractor shall be solely responsible for all bonding costs, regardless of amount of work performed. Permit fees are not considered overhead and shall be billed as part of work.

Markups for purchased supplies and rental equipment/tools and specialty subcontractors:

Contractor shall have machinery, vehicles, equipment, and personnel to perform work as outlined in the bid proposal form, however, should rental machinery/equipment or specialty subcontractors be required for items not covered in the bid proposal form (i.e. major traffic control, etc.), then ECUA must pre-approve rental rate and rental timeframe and subcontractor use and will reimburse contractor for costs plus 10% mark-up.

ECUA will allow a 10% mark-up on all supplies that are purchased and used on this contract; however, Contractor must check with Lift Stations Supervisor for available supplies prior to purchasing separately. Material, rental, and sub-contractor invoices shall be submitted to ECUA as part of the invoice process.

Payment and warranty terms: Payment is net 30 days. Standard ECUA warranty of 2 years beginning at the date of ECUA payment applies to all work performed under this contract.

Additional work not itemized in bid proposal form: Contractor shall be capable of performing other construction related tasks not specifically listed in the bid proposal form – activities such as standard traffic control, bypass pumping, etc. and shall be prepared to perform or coordinate sub-contractors on activities. Permission from ECUA is required prior to Contractor utilizing any items or subs not listed in this contract.

Minimum charge: Should ECUA direct contractor to perform an individual task that is so small in scale that it requires less than 4 hours, ECUA will pay for maximum 4 hours of use. This does not apply to tasks requiring multiple days where a contractor may need to perform less than 4 hours work on a partial day. It does not apply to field visits or meetings either.

Contractor Licensing: Contractor will be required to have a valid State of Florida General Contractor's License with 5 years of experience in performing this type of work or possess a valid Florida Certified Underground Utility and Excavation Contractor License.

Insurance: The successful contractor will be required to supply insurance certificate(s) to ECUA prior to the start of the contract. (See Risk Management Insurance Requirements)

Contract Length: It is anticipated that this contract will start September 1, 2013 and remain in effect until August 31, 2014 (with two one-year optional extensions upon mutual agreement of both parties, with no increase in price). The renewal request shall be in writing and is subject to the same terms and conditions set forth in the initial contract.

ADDITIONAL SECURITY REQUIREMENTS

Due to the need for increased protection measures at ECUA facilities, additional security requirements are necessary for these sites. For security purposes, contractor personnel requiring access to ECUA facilities must provide the results of, a criminal history background check to ECUA prior to initiation of work on site. Criminal history checks must be conducted by/through a law enforcement agency, or agency having access to such information. Public records checks are not acceptable. Additionally, an ECUA background/criminal history information form must be completed by all personnel requiring access to an ECUA facility. Completed materials will be

submitted to the ECUA Director of Shared Services, Randy Rudd, and will be protected from disclosure to the extent allowable by law.

In addition, access to these sites will be permitted only upon proof of satisfactorily passing a drug test, administered through a certified laboratory.

Background checks and drug testing conducted as part of pre-employment screenings will satisfy this requirement, if completed within 30 days of the contract award date.

ECUA Contact: Joe Tindall, 850-969-3375 or Gerry Piscopo 850-969-6690. For information pertaining to the bid package, contact Amy Williamson, 850-969-6531 or email to amy.williamson@ecua.fl.gov.

**RISK MANAGEMENT POLICY AND STANDARDS
FOR
AGREEMENTS, CONTRACTS AND LEASES**

DEFINITIONS

The following definitions apply to these Risk Management Provisions:

Contract - The contract or agreement of which these Risk Management Provisions are a part for the construction, alteration, repair, or demolition of a structure or facility.

Organization - The Emerald Coast Utilities Authority, a local governmental body of the State of Florida, its Board, officers, employees, volunteers, representatives, and agents.

Other Party - The other party to the Contract of which these Risk Management Provisions are a part, any subsidiaries or affiliates, officers, employees, volunteers, representatives, agents, contractors, and subcontractors.

HOLD HARMLESS

The Other Party agrees to hold the Organization and the members of its governing board and its other officers and employees harmless against all claims for bodily injury, sickness, disease, death, personal injury, or damage to property or loss of use resulting therefrom, arising out of or related to the Contract, to the extent such claims are caused by the negligence, recklessness, or intentional wrongful misconduct of the Other Party and persons or entities employed or utilized by the Other Party in the performance of the Contract.

PAYMENT ON BEHALF OF ORGANIZATION

The Other Party agrees to pay on behalf of the Organization all claims described in the above "Hold Harmless" paragraph, and to pay the reasonable costs and fees of the attorneys selected by the Organization, at trial and on appeal, to defend the Organization and its officers and employees against such claims. Provided, however, that the total liability of the Other Party to the Organization under the above "Hold Harmless" paragraph and this "Payment on Behalf of Organization" paragraph shall not exceed the sum of One Million Dollars (\$1,000,000) per claim or occurrence.

Such payment on behalf of the Organization shall be in addition to any and all other legal remedies available to the Organization and shall not be considered to the exclusive remedy of the Organization.

LOSS CONTROLS/SAFETY

Precaution shall be exercised at all times by the Other Party for the protection of all persons, including employees, and property. The Other Party shall comply with all laws, regulations, or ordinances relating to safety and health, and shall make special effort to detect hazardous conditions and shall take prompt action where loss control/safety measures should reasonably be expected.

The Organization may order work to be stopped if conditions exist that present immediate danger to persons or property. The Other party acknowledges that such stoppage will not shift responsibility for any loss or damages from the Other Party to the Organization.

SEVERABILITY

The provisions of these Risk Management Provisions are severable. In the event a court of competent jurisdiction should declare any provision of these Risk Management Provisions to be void or contrary to public policy such provision shall be stricken from these Risk Management Provisions, and the remaining provisions shall be enforced as though the provision determined to be void or contrary to public policy had not been included herein.

INSURANCE - BASIC COVERAGES REQUIRED

The Other Party shall procure and maintain the following described insurance, except for coverages specifically waived by the Organization, on policies and with insurers acceptable to the Organization. These insurers shall have A.M. Best (or equivalent) rating of no less than A:VII unless otherwise agreed to by the Organization.

These insurance requirements shall not limit the liability of the Other Party. The Organization does not represent these types or amounts of insurance to be sufficient or adequate to protect the Other Party's interests or liabilities, but are merely minimums.

Except for workers compensation, the Other Party waives its right of recovery against the Organization, to the extent permitted by its insurance policies.

The Other Party's deductibles/self-insured retentions shall be disclosed to the Organization and may be disapproved by the Organization. They shall be reduced or eliminated at the option of the Organization. The Other Party is responsible for the amount of any deductible or self-insured retention.

Insurance required of the Other Party or any other insurance of the Other Party shall be considered primary, and insurance of the Organization, if any, shall be considered excess, as may be applicable to claims which arise out of the Hold Harmless, Payment on Behalf of Organization, Insurance, Certificates of Insurance and any Additional Insurance provisions of this agreement, contract or lease.

Additional Insured

Except for workers compensation and professional liability, the Other Party's insurance policies shall be endorsed to name the Organization as an additional insured for "bodily injury", "property damage" or "personal and advertising injury" caused, in whole or in part, by the Other Party's acts or omissions; or the acts or omissions of those acting on the Other Party's behalf; in the performance of the Other Party's ongoing operations for the Organization. The preferred Commercial General Liability coverage endorsement is ISO Form CG 20 10.

Workers Compensation Coverage

The Other Party shall purchase and maintain workers compensation insurance for all workers compensation obligations imposed by state law and employer's liability limits of at least \$100,000 each accident and \$100,000 each employee/\$500,000 policy limit for disease.

The Other Party shall also purchase any other coverages required by law for the benefit of employees.

General, Automobile and Excess or Umbrella Liability Coverage

The Other Party shall purchase and maintain coverage on forms no more restrictive than the latest editions of the Commercial General Liability and Business Auto policies of the Insurance Services Office.

Minimum limits of \$1,000,000 per occurrence for all liability must be provided, with excess or umbrella insurance making up the difference, if any, between the policy limits of underlying policies (including employers liability required in the Workers Compensation Coverage section) and the total amount of coverage required.

Commercial General Liability Coverage - Occurrence Form Required

Coverage A shall include bodily injury and property damage liability for premises, operations, products and completed operations, independent contractors, contractual liability covering this agreement, contract or lease, broad form property damage, and property damage resulting from explosion, collapse or underground (x,c,u) exposures.

Coverage B shall include personal injury.

Coverage C, medical payments, is not required.

The Other Party is required to continue to purchase products and completed operations coverage, at least to satisfy this agreement, contract or lease, for a minimum of three years beyond the Organization's acceptance of renovation or construction projects.

Business Auto Liability Coverage

Business Auto Liability coverage is to include bodily injury and property damage arising out of ownership, maintenance or use of any auto, including owned, nonowned and hired automobiles and employee nonownership use.

Excess or Umbrella Liability Coverage

Umbrella Liability insurance is preferred, but an Excess Liability equivalent may be allowed. Whichever type of coverage is provided, it should be at least "following form" and shall not be more restrictive than the underlying insurance policy coverages.

EVIDENCE/CERTIFICATES OF INSURANCE

Required insurance shall be documented in Certificates of Insurance, including indication that the policy(s) is endorsed to provide the Organization at least 30 days in advance notice of cancellation, nonrenewal or adverse change.

New Certificates of Insurance are to be provided to the Organization at least 15 days prior to coverage renewals.

If requested by the Organization, the Other Party shall furnish complete copies of the Other Party's insurance policies, forms and endorsements.

For Commercial General Liability coverage the Other Party shall, at the option of the Organization, provide an indication of the amount of claims payments or reserves chargeable to the aggregate amount of liability coverage.

Receipt of certificates or other documentation of insurance or policies or copies of policies by the Organization, or by any of its representatives, which indicate less coverage than required does not constitute a waiver of the Other Party's obligation to fulfill the insurance requirements herein.

ADDITIONAL INSURANCE

If checked below, the Organization requires the following additional types of insurance.

Property Coverage for Leases

The Other Party shall procure and maintain for the life of the lease, all risk/special perils (including sinkhole) property insurance (or its equivalent) to cover loss resulting from damage to or destruction of the building, improvements and personal property/contents. The policy shall cover 100% replacement cost, and shall include an agreed value endorsement to waive coinsurance.

Coverage shall also include continued full payment of rents to the Organization for up to one year after damage or destruction of the property.

Commercial General Liability Coverage Project Aggregate

Because the Commercial General Liability form of coverage includes an annual aggregate limitation on the amount of insurance provided, a separate project aggregate limit of \$_____ is required by the Organization for this agreement or contract.

Liquor Liability Coverage

In anticipation of alcohol being served, the Other Party shall provide evidence of coverage for liquor liability in an amount equal to the general/umbrella/excess liability coverage. If the general liability insurance covers liquor liability (e.g. host or other coverage), the Other Party's agent or insurer should provide written documentation to confirm that coverage already applies to this agreement, contract or lease. If needed coverage is not included in the general/umbrella/excess liability policy(ies), the policy(ies) must be endorsed to extend coverage for liquor liability, or a separate policy must be purchased to provide liquor liability coverage in the amount required.

Owners Protective Liability Coverage

For renovation or construction contracts the Other Party shall provide for the Organization an owners protective liability insurance policy (preferably through the Other Party's insurer) in the name of the Organization.

This is redundant coverage if the Organization is named as an additional insured in the Other Party's Commercial General Liability insurance policy. However, this separate policy may be the only source of coverage if the Other Party's liability coverage limit is used up by other claims.

Builders Risk Coverage

Builders Risk insurance is to be purchased to cover subject property for special perils (all risks or equivalent) of loss (including theft and sinkhole), subject to a waiver of coinsurance, and covering on-site and off-site storage, transit and installation risks as indicated in the Installation Floater and Motor Truck Cargo insurance described hereafter, if such coverages are not separately provided.

If flood and/or earthquake risks exist, flood and/or earthquake insurance are to be purchased.

If there is loss of income, extra expense and/or expediting expense exposure, such coverage is to be purchased.

If boiler and machinery risks are involved, boiler and machinery insurance, including coverage for testing, is to be purchased.

The Builders Risk insurance is to be endorsed to cover the interests of all parties, including the Organization and all contractors and subcontractors. The insurance is to be endorsed to cover testing and to grant permission to occupy.

Installation Floater Coverage

Installation Floater insurance is to be purchased when Builder's Risk insurance is inappropriate, or when Builder's Risk insurance will not respond, to cover damage or destruction to renovations, repairs or equipment being installed or otherwise being handled or stored by the Other Party, including off-site storage, transit and installation. The amount of coverage should be adequate to provide full replacement value of the property, repairs, additions or equipment being installed, otherwise being handled or stored on or off premises. All risks coverage is preferred.

Motor Truck Cargo Coverage

If the Installation Floater insurance does not provide transportation coverage, separate Motor Truck Cargo or Transportation insurance is to be provided for materials or equipment transported in the Other Party's or other vehicles from place of receipt to building sites or other storage sites. All risks coverage is preferred.

Contractor's Equipment Coverage

Contractor's Equipment insurance is to be purchased to cover loss of equipment and machinery utilized in the performance of work by the Other Party. All risks coverage is preferred.

Fidelity/Dishonesty Coverage - for Employer

Fidelity/Dishonesty insurance is to be purchased to cover dishonest acts of the Other Party's employees, including but not limited to theft of vehicles, materials, supplies, equipment, tools, etc., especially property necessary to work performed.

Fidelity/Dishonesty/Liability Coverage - for Organization

Fidelity/Dishonesty/Liability insurance is to be purchased or extended to cover dishonest acts of the Other Party's employees resulting in loss to the Organization.

Garage Liability Coverage

Garage Liability insurance is to be purchased to cover the Other Party and its employees for its garage and related operations while in the care, custody and control of the Organization's vehicles.

Garagekeepers Coverage (Legal Liability Form)

Garagekeepers Liability insurance is to be purchased to cover the Other Party's liability for damage or other loss, including comprehensive and collision risks, to the Organization's vehicles while in the care, custody and control of the Other Party. This form of coverage responds only when the Other Party is legally liable for the loss.

Garagekeepers Coverage (Direct-Excess Form)

Garagekeepers Liability insurance is to be purchased to cover damage or other loss, including comprehensive and collision risks, to the Organization's vehicles while in the care, custody and control of the Other Party. This form of coverage responds on a legal liability basis, and also without regard to legal liability on an excess basis over any other collectible insurance.

Watercraft Liability Coverage

Because the Other Party's provision of services involves utilization of watercraft, watercraft liability coverage must be provided to include bodily injury and property damage arising out of ownership, maintenance or use of any watercraft, including owned, nonowned and hired.

Coverage may be provided in the form of an endorsement to the general liability policy, or in the form of a separate policy covering Watercraft Liability or Protection and Indemnity for bodily injury and property damage.

United States Longshoremen and Harborworkers Act Coverage

The Workers Compensation policy is to be endorsed to include United States Longshoremen and Harborworkers Act Coverage for exposures which may arise from this agreement or contract.

Jones Act Coverage

The Workers Compensation policy is to be endorsed to include Jones Act Coverage for applicable exposures (for work on, over or in navigable waters) which may arise from this agreement or contract.

Aircraft Liability Coverage

Because the Other Party's provision of services involves utilization of aircraft, aircraft liability coverage must be provided to include bodily injury and property damage arising out of ownership, maintenance or use of any aircraft, including owned, nonowned and hired.

The minimum limits of coverage shall be \$____,000,000 per occurrence, Combined Single Limit for Bodily Injury (including passenger liability) and Property Damage.

Pollution/Environmental Impairment Liability Coverage

Pollution/environmental impairment liability insurance is to be purchased to cover pollution and/or environmental impairment which may arise from this agreement or contract. The recommended minimum coverage is \$1,000,000. The coverage period shall be extended beyond the date of the completed project, until the expiration date of the performance bond.

Limited Pollution Liability – Commercial General Liability (CGL) with Endorsement

Covers third-party damages caused by the accidental release of pollutants at a work site. Covers pollution incidents that commence during the policy period. The minimum limits of coverage shall be \$1,000,000. Defense costs outside the limit of liability. Coverage is provided for gradual releases. Includes clean-up costs if part of otherwise covered property damage.

PROFESSIONAL LIABILITY, MALPRACTICE AND/OR ERRORS OR OMISSIONS

If checked below, the Organization requires the following terms and types of insurance for professional, malpractice, and errors or omissions liability.

Hold Harmless

The following replaces the previous Hold Harmless wording.

The Organization shall be held harmless against all claims for bodily injury, sickness, disease, death or personal injury or damage to property or loss of use resulting therefrom arising out of performance of the agreement or contract, unless such claims are a result of the Organization's sole negligence.

The Organization shall also be held harmless against all claims for financial loss with respect to the provision of or failure to provide professional or other services resulting in professional, malpractice, or errors or omissions liability arising out of performance of the agreement or contract, unless such claims are a result of the Organization's sole negligence.

Professional Liability/Malpractice/Errors or Omissions Insurance

The Other Party shall purchase and maintain professional liability or malpractice or errors or omissions insurance with minimum limits of \$___,000,000 per occurrence.

If a claims made form of coverage is provided, the retroactive date of coverage shall be no later than the inception date of claims made coverage, unless the prior policy was extended indefinitely to cover prior acts.

Coverage shall be extended beyond the policy year either by a supplemental extended reporting period (ERP) of as great duration as available, and with no less coverage and with reinstated aggregate limits, or by requiring that any new policy provide a retroactive date no later than the inception date of claims made coverage.

The Other Party shall procure and maintain the following described insurance, except for coverages specifically waived by the Organization, on policies and with insurers acceptable to the Organization.

These insurance requirements shall not limit the liability of the Other Party. The Organization does not represent these types or amounts of insurance to be sufficient or adequate to protect the Other Party's interests or liabilities, but are merely minimums.

Except for workers compensation, the Other Party waives its right of recovery against the Organization, to the extent permitted by its insurance policies.

The Other Party's deductibles/self-insured retentions shall be disclosed to the Organization and may be disapproved by the Organization. They shall be reduced or eliminated at the option of the Organization. The Other Party is responsible for the amount of any deductible or self-insured retention.

Insurance required of the Other Party or any other insurance of the Other Party shall be considered primary, and insurance of the Organization shall be considered excess, as may be applicable to claims which arise out of the Hold Harmless, Payment on Behalf of Organization, Insurance, Certificates of Insurance and any Additional Insurance provisions of this agreement, contract or lease.

EMERALD COAST UTILITIES AUTHORITY

GENERAL PROVISIONS

PURCHASE ORDER/CONTRACT

1. Supplies are of domestic origin unless indicated by quoter.
- 1a .If you are unable to quote, please advise. This request does not commit Emerald Coast Utilities Authority to pay any cost incurred in the preparation or submission of this quotation or to procure or contract for supplies or services.
2. DELIVERY, INSPECTION AND ACCEPTANCE – Delivery, inspection and acceptance will be at destination unless otherwise provided. Until delivery and acceptance and after any rejections, risk of loss will be on the Contractor unless loss results from negligence of ECUA. Notwithstanding the requirements for any ECUA inspection and test contained in specifications applicable to this contract, except where specialized inspections or tests are specified for performance solely by ECUA, the contractor shall perform or have performed the inspections and tests required to substantiate that the supplies and services provided under the contract conform to the drawings, specifications, and contract requirements listed herein, including if applicable, the technical requirements for the manufacturer’s part numbers specified herein.
3. ENTIRE AGREEMENT – The terms, specifications and drawings included in this order when duly executed constitute the entire agreement between the parties unless otherwise stated on the face of the order. No modification or waiver of terms of this agreement shall be binding unless in writing signed by a duly authorized representative of ECUA and confirmed by such a representative of the Vendor. This agreement shall be interpreted in accordance with the laws of the State of Florida.
4. DELIVERY OF EXCESS QUANTITIES OF \$100 OR LESS – The Contractor is responsible for the delivery of each item quantity; within allowable variations, if any. If the Contractor delivers and ECUA receives quantities of any item in excess of the quantity called for (after considering any allowable variation in quantity) such excess quantities will be treated as being delivered for the convenience of the Contractor. ECUA may retain such excess quantities up to \$100 in value without compensating the interests therein. Quantities in excess of \$100 will, at the option of ECUA, either be returned at the Contractor’s expense or retained and paid for by ECUA at the contract unit price.
- 4a .DELIVERIES – In the event of failure to deliver material of the quality or within the time specified, ECUA may cancel order and buy elsewhere. Failure of ECUA to exercise this option with respect to any installment shall not be deemed a waiver with respect to future installments, if any.

5. DELIVERY TICKETS – All shipments under this agreement shall be accompanied with delivery tickets, or sales slips, in triplicate, which shall contain the following minimum information.
 - a. Name of supplier;
 - b. Blanket Purchase Order number;
 - c. Date of Call;
 - d. Call number;
 - e. Itemized list of supplies or services furnished;
 - f. Quantity, unit price and extension of each item, less applicable discounts (unit price and extensions need not be shown when incompatible with the use of automated systems, provided that the invoice is itemized to show this information); and
 - g. Date of delivery or shipment.Upon delivery, the receiving office will retain one copy of the related delivery ticket and will sign the other two copies and return them to the supplier or his agent. One of these copies may subsequently be required to support the invoice.
6. PAYMENTS – Invoices shall be submitted in triplicate (one copy shall be marked “Original”) unless otherwise specified, and shall contain the following information: Contract or Order number, item number, contract description of supplies or services, sizes, quantities, unit prices and extended totals. Bill of Lading number and weight of shipment will be shown for shipments of Bills of Lading. Unless otherwise specified, payment will be made on partial deliveries accepted by ECUA when the amount due on such deliveries so warrants.
7. DISCOUNTS – In connection with any discount offered, time will be computed from date of delivery suppliers to carrier when acceptance is at the point of origin or from date of delivery at destination when delivery and acceptance are at these points or from the date the correct invoice or voucher is received in the office specified by ECUA, if the latter is later than date of delivery. Payment is deemed to be made for the purpose of earning the discount on the date of mailing of the ECUA check.
8. CONVICT LABOR – In connection with the performance of work under this contract, the Contractor agrees not to employ any person undergoing sentence of imprisonment except as provided by Public Law 89.176, September 10, 1965 (18 U.S.C. 40821ch21) Executive Order 11755, December 29, 1973.
9. COVENANT AGAINST CONTINGENT FEES – The Contractor warrants that no person or selling agency has been employed or retained to solicit or secure this contract upon agreement or understanding for a commission, percentage, brokerage, or contingent fee, excepting bona fide employees or bona fide established commercial or selling agencies maintained by the Contractor for the purpose of securing business. For breach or violation of this warranty ECUA shall have the right to annul this contract without liability or in its discretion to deduct from the contract price or consideration or otherwise recover, the full amount of such commission, percentage, brokerage, or contingent fee.

- 10a. CONTINGENCIES – Neither party shall be liable for delays or defaults due to acts of God, government authority or public enemy, war, fires, floods, epidemics, strikes, labor troubles, freight embargoes, or contingencies reasonably beyond its control. The party so affected upon prompt written notice to the other party shall be excused from making or taking deliveries hereunder to the extent of such prevention or restriction. At ECUA’s option, deliveries so omitted shall be made on notice thereof to the Vendor, upon cessation of such contingency even though such might have been operative at the date of this order.
10. GRATUITIES – (a) ECUA may, by written notice to the Contractor, terminate the right of the Contractor to proceed under this contract if it is found after notice and hearing by the Executive Director or his duly authorized representative, that gratuities (in the form of entertainment, gifts or otherwise) were offered or given by the Contractor, or any agent or representative of the Contractor, to any officer or employee of ECUA with a view toward securing a contract or securing favorable treatment with respect to the awarding or amending, or the making of any determinations with respect to the performing of such contract, provided, that the existence of the facts upon which the Executive Director or his duly authorized representative make such findings shall be in issue and may be reviewed in any competent court, (b) in the event this contract is terminated as provided in paragraph (a) hereof, ECUA shall be entitled (1) to pursue the same remedies against the Contractor as it could pursue in the event of a breach of the contract by the Contractor and (2) as a penalty and in addition to any other damages to which it may be entitled by law to exemplary damages in an amount (as determined by the Executive Director or his duly authorized representative) which shall be not less than three nor more than ten times the costs incurred by the Contractor in providing any such gratuities to any such officer or employee, (c) The rights and remedies of ECUA provided in this clause shall not be exclusive or in addition to any other rights and remedies provided by law or under the contract.
11. CONDITION FOR ASSIGNMENT – This (contract or purchase order) shall not be assigned in full or in part without the consent of ECUA. Such consent shall not relieve the Contractor from its obligations and liabilities.
12. GOVERNMENT REGULATIONS – Vendor warrants that all applicable laws and regulations of governmental authority, covering the production, sale and delivery of the materials specified herein, have complied with and shall indemnify and save ECUA harmless from and against any liability or loss resulting from Vendor’s failure to do so.
13. TAXES – ECUA is exempt from Federal Taxes on transportation charges and any Federal Excise Tax. If you prepaid transportation, do not pay tax as ECUA will not reimburse you for the taxes paid. ECUA is exempt from State Sales Tax.
14. CHANGES – The Purchasing and Stores Manager may at any time, by written order, and without notice to the sureties, make changes, within the general scope of this contract, in (i) drawings, designs, or specifications, where the supplies to be furnished are to be specially manufactured for ECUA in accordance therewith; (ii) method of shipment or packing and (iii) place of delivery. If any such change causes an increase or decrease in the cost of, or the time required for the performance of this contract, whether changed or not changed by any such order, an equitable adjustment shall be made by written modification of this contract.

Any claim by the Contractor for adjustment under this clause must be asserted within 30 days from the date of receipt by the Contractor of the notification of change provided that the Purchasing and Stores Manager, if he decides that the facts justify such action, may receive and act upon any such claim asserted prior to final payment, under the contract. Failure to agree to any adjustment shall be a dispute concerning a question of fact within the meaning of the clause of this contract entitled "Disputes." However, nothing in this clause shall excuse the Contractor from proceeding with this contract as changed.

15. **TERMINATION FOR DEFAULT** – The Purchasing and Stores Manager, by written notice, may terminate this contract, in whole or in part, for failure of the Contractor to perform any of the provisions hereof, in such event, the Contractor shall be liable for damages; including the excess cost of reprocurring similar supplies or services; provided that if (i) it is determined for any reason that the Contractor was not in default or (ii) the Contractor's failure to perform is without his and his subcontractors control, fault or negligence, the termination shall be deemed to be a termination for convenience under paragraph 17. As used in this provision the term "subcontractor" and "subcontractors" means subcontractors at any tier.
16. **TERMINATION FOR CONVENIENCE** – The Purchasing and Stores Manager, by written notice, may terminate this contract, in whole or in part, when it is in the best interest of ECUA. If this contract is for supplies and is so terminated, the Contractor shall be compensated for goods delivered and accepted up to the date of termination at the discretion of the Executive Director. To the extent that this contract is for services and is so terminated, ECUA shall be liable only for payment in accordance with the payment provisions of this contract for services rendered prior to the effective date of termination.
17. **ASSIGNMENT OF CLAIMS** – Claims for monies due or to become due under this Contract shall be assigned only pursuant to the Assignment of Claims Act of 1940, as amended (31 U.S.C 203, 41 U.S.C. 15). However, payments to an assignee of monies under this contract shall not, to the extent provided in said Act, as amended be subject to reduction or set-off (see Clause 12).
18. **EXTENT OF OBLIGATION** – ECUA is obligated under a call-type Purchase Order only to the extent of authorized calls actually placed against this agreement.
19. **PRICING** – The prices to ECUA for all purchases made under this Agreement shall be as low as or lower than those charged the suppliers most favored customer, in addition to any discounts for prompt payment.
20. **WARRANTIES** – In addition to all warranties, established by statute or common law or set forth elsewhere in this order. The Vendor expressly warrants that all material or services covered herein shall conform to all specifications, drawings, samples, and descriptions furnished or adopted by ECUA and shall be of the best quality and fit and sufficient for the purpose for which purchased, if specified hereon, merchantable of good material and workmanship and free from all patent and patent defects. ECUA's failure to give notice to Vendor of any breach of warranty shall not discharge Vendor's liability therefore. Without limiting the generality of the foregoing, Vendor agrees to be responsible for all defects in

design, workmanship and materials, which may become apparent within twelve months of receipt by ECUA.

21. PATENTS – Vendor shall protect and indemnify ECUA against all claims, judgments and expenses arising from infringement or any patent by any of the goods delivered hereunder. Vendor shall defend or settle at its own expense any proceeding brought against ECUA for such infringement provided Vendor is notified promptly of the commencement of such proceeding and is given authority, information and assistance by ECUA for the defense or settlement thereof.
22. INSTALLATION – If this order required the services of ECUA experts or employees of ECUA safety rules and fire regulations, Vendor assumes full responsibility for their acts and omissions and agrees to save ECUA harmless from any claims arising therefrom and to accept exclusive liability for payroll and other taxes imposed upon the employer by law. Vendor will undertake to keep the materials and premises involved free from any lien whatever for materials and labor incident to the performance of Vendor's obligations hereunder. If Vendor furnishes materials and services for construction and improvement of realty and the installation of personalty for a lump sum amount, Vendor agrees to furnish an analysis thereof as ECUA may reasonably require for accounting purposes. Vendor shall be solely responsible for materials furnished by ECUA on other than a charge basis in connection with this order.
23. NON-DISCLOSURE – Without prior written consent of ECUA in each instance, Vendor shall not reveal to a third party the details, characteristics or any information on materials made to the special order for ECUA or use reproductions thereof and any promotional media or reveal that, ECUA is purchasing the materials hereunder.
24. COMMERCIAL WARRANTY – The Contractor agrees that the supplies or services furnished under this contract shall be covered by the most favorable commercial warranties the Contractor gives to any customer for such supplies or services and that the rights and remedies provided herein are in addition to and do not limit any rights to the Emerald Coast Utilities Authority by any other clause of this contract.
25. DEVIATION FROM SPECIFICATIONS – Emerald Coast Utilities Authority has the sole authority to determine if any deviation from the specifications cited is acceptable.

CERTIFICATION OF NONSEGREGATED FACILITIES

By the submission of this bid, the bidder, offeror, applicant, or subcontractor certifies that he does not maintain or provide for his employees any segregated facilities at any of his establishments, and that he does not permit his employees to perform their services at any location under his control, where segregated facilities are maintained. He certifies further that he will not maintain or provide for his employees any segregated facilities at any of his establishments, and that he will not permit his employees to perform their services at any location, under his control, where segregated facilities are maintained. The bidder, offeror, applicant, or subcontractor agrees that a breach of this certification is a violation of the Equal Opportunity Clause in this contract. As used in this certification, the term "segregated facilities" means any waiting rooms, work areas, rest rooms and wash rooms, restaurants and other eating areas, time clocks, locker rooms and other storage or dressing areas, parking lots, drinking fountains, recreation or entertainment areas, transportation, and housing facilities provided for employees which are segregated by explicit directive or are in fact segregated on the basis of race, color, religion or national origin, because of habit, local custom, or otherwise. He further agrees that (except where he has obtained identical certifications from proposed subcontractors for specific time periods) he will obtain identical certifications from proposed subcontractors prior to the award of subcontracts or purchase orders exceeding \$10,000; that he will retain such certifications in his files and make them available to the Emerald Coast Utilities Authority upon request.

Provided, however, that such certifications shall not be required in the case of purchase orders or contracts which, in case of a Federal Government contract or subcontract, would be exempt from compliance with the Equal Opportunity Clause by 41 CFR S60-1.5. This section provides for the exemption of transactions not exceeding \$10,000, contracts and subcontracts for indefinite quantities established not to exceed \$10,000 in any contract year, contracts with certain educational institutions, work on or near Indian reservations, facilities (including, but not limited to, agencies, instrumentalities or subdivision of state or local government) which are separate and distinct from activities of the prime contractor or subcontractor related to the performance of the contract or subcontract, and emergencies involving national security.

Signature Date

Name & Title of Signer

DRUG-FREE WORKPLACE FORM

The undersigned vendor in accordance with Florida Statute 287.087 hereby certifies that _____ does:

(Name of Business)

1. Publish a statement notifying employees that the unlawful manufacture, distribution, dispensing, possession, or use of a controlled substance is prohibited in the workplace and specifying the actions that will be taken against employees for violations of such prohibition.
2. Inform employees about the dangers of drug abuse in the workplace, the business’s policy of maintaining a drug-free workplace, any available drug counseling, rehabilitation, and employee assistance programs, and the penalties that may be imposed upon employees for drug abuse violations.
3. Give each employee engaged in providing the commodities or contractual services that are under bid a copy of the statement specified in subsection (1).
4. In the statement specified in subsection (1), notify the employees that, as a condition of working on the commodities or contractual services that are under bid, the employee will abide by the terms of the statement and will notify the employer of any conviction of, or plea of guilty or nolo contendere to, any violation of Chapter 1893 or of any controlled substance law of the United States or any state, for a violation occurring in the workplace no later than five (5) days after such conviction.
5. Impose a sanction on, or require the satisfactory participation in a drug abuse assistance or rehabilitation program if such is available in the employee’s community, by any employee who is so convicted.
6. Make a good faith effort to continue to maintain a drug-free workplace through implementation of this section.

As the person authorized to sign the statement, I certify that this firm complies fully with the above requirements.

Bidder’s Signature

Date

Company: _____

Bid/RFP/PO: _____

EMERALD COAST UTILITIES AUTHORITY

BID NUMBER: 2013-13

PROPOSAL FORM

TO: EMERALD COAST UTILITIES AUTHORITY DATE: _____
PENSACOLA, FLORIDA

GENTLEMEN:

IN ACCORDANCE WITH YOUR REQUEST FOR BIDS, INSTRUCTIONS AND SPECIFICATIONS, ATTACHED THERETO, AND SUBJECT TO ALL CONDITIONS THEREOF, I (WE), THE UNDERSIGNED, HEREBY PROPOSE AND AGREE IF THIS PROPOSAL IS ACCEPTED, TO CONTRACT WITH THE EMERALD COAST UTILITIES AUTHORITY TO FURNISH ANY ITEMS REQUESTED HEREIN AND DELIVER SAME WITHOUT ADDITIONAL COST TO THE EMERALD COAST UTILITIES AUTHORITY AT THE SPECIFIED LOCATION FOR THE BID(S) LISTED BELOW.

THE UNDERSIGNED FURTHER DECLARES THAT HE HAS CAREFULLY EXAMINED THE SPECIFICATIONS AND IS THOROUGHLY FAMILIAR WITH THEM AND THEIR PROVISIONS. HE FURTHER DECLARES THAT NO OTHER PERSON OTHER THAN THE BIDDER HEREIN NAMED HAS ANY INTEREST IN THIS PROPOSAL OR IN THE CONTRACT TO BE EXECUTED, AND THAT IT IS MADE WITHOUT ANY CONNECTION WITH ANY OTHER PERSON(S) MAKING PROPOSAL FOR THE SAME ARTICLES, AND IT IS IN ALL RESPECTS FAIR AND WITHOUT COLLUSION AND FRAUD.

(QUANTITIES ARE SUBJECT TO MODIFICATION)

FAILURE TO PROVIDE ALL OF THE FOLLOWING INFORMATION MAY RESULT IN AUTOMATIC REJECTION OF BID.

CONTRACT DURATION: SEPTEMBER 1, 2013 THROUGH AUGUST 31, 2014 ONE-YEAR CONTRACT WITH TWO ONE-YEAR OPTIONAL EXTENSIONS UPON MUTUAL AGREEMENT OF BOTH PARTIES, WITH NO INCREASE IN PRICE).

| Description | Unit | Unit Price | Extension |
|-----------------------------------------------|-------------|-------------------|------------------|
| Project manager (regular hours) | HR | | |
| Supervisor (regular hours) | HR | | |
| Operator (regular hours) | HR | | |
| Laborer (regular hours) | HR | | |
| Project Manager (overtime hours) | HR | | |
| Supervisor (overtime hours) | HR | | |
| Operator (overtime hours) | HR | | |
| Laborer (overtime hours) | HR | | |
| Supervisor pick-up truck (incl typical tools) | HR | | |
| Crew truck (incl. typical tools) | HR | | |
| 40' bucket truck | HR | | |
| Mobilization/demobilization | EA | | |
| Full size excavator | HR | | |
| Backhoe/mini excavator | HR | | |
| Tractor and bush hog | HR | | |
| Stump grinder | HR | | |
| Trailer | HR | | |
| Debris Disposal container | HR | | |
| Skid steer | HR | | |
| Plate compactor | HR | | |
| Bahama rock road base materials | CY | | |
| Crushed concrete road base materials | CY | | |
| Asphalt milling road base materials | CY | | |
| Lime Rock road base materials | CY | | |
| Silt fencing | EA | | |
| Sod, hay, seeding | EA | | |
| Rebar | FT | | |
| Culvert pipe | EA | | |
| | | | |
| | | | |
| | | | |
| | | | |
| | | | |
| | | | |
| | | | |
| | | | |
| | | | |

EXCEPTIONS: YES _____ NO _____

(EXCEPTIONS INCLUDE THE WHOLE BID DOCUMENT, OUR SPECIFICATIONS, INSTRUCTIONS TO BIDDERS AND GENERAL PROVISIONS).

DELIVERY SCHEDULE: _____ BIDDER: _____

(FOB PENSACOLA) BY: _____
(PRINT OR TYPE)

TERMS OF PAYMENT: _____ SIGNATURE: _____

(NET 30 UNLESS TITLE: _____
DISCOUNT OFFERED) ADDRESS: _____

TELEPHONE:() _____

FAX NUMBER:() _____

FEID NUMBER: _____

E-MAIL: _____

IT IS ESSENTIAL THAT THE SUBMISSION INCLUDE SIGNED AFFIDAVITS ON THE BELOW LISTED FORMS.

EXECUTED ATTACHED FORMS:

____ PROPOSAL FORM

____ DRUG-FREE WORKPLACE FORM

____ EQUAL OPPORTUNITY FORM

____ CERTIFICATION OF NONSEGREGATED FACILITIES FORM

**(This page intentionally left
blank)**