

K:\279\27941.05 - Bayou Marcus\DWG\M-200.dwg, Jun 05, 2012 - 1:58:35PM, toverton

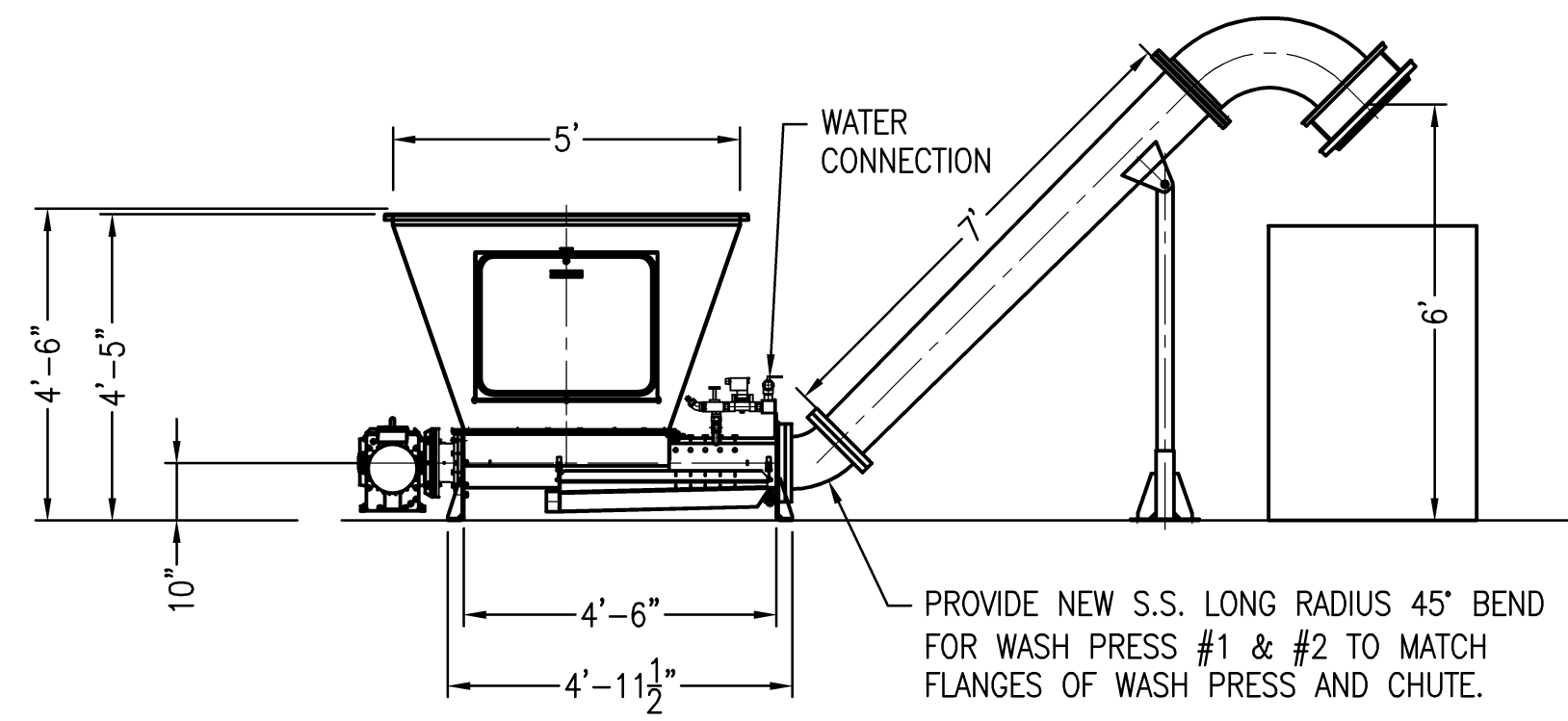

ELEVATION

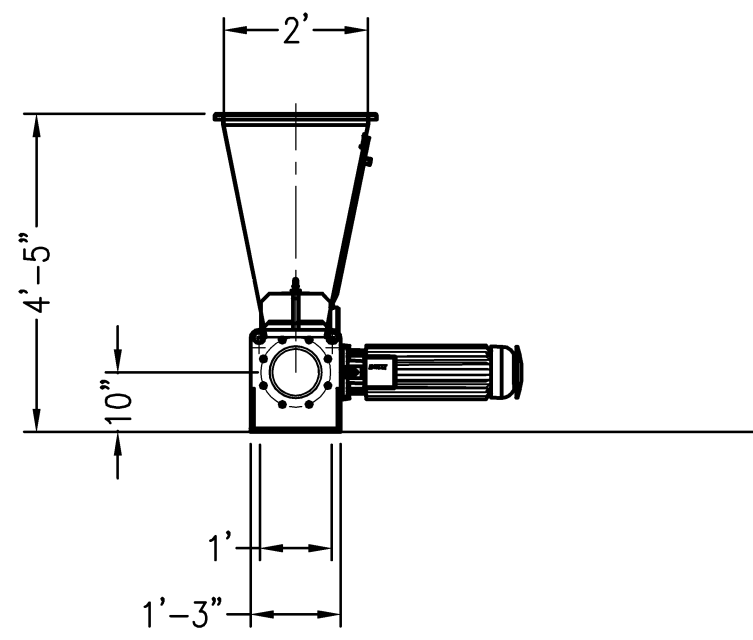

SECTION

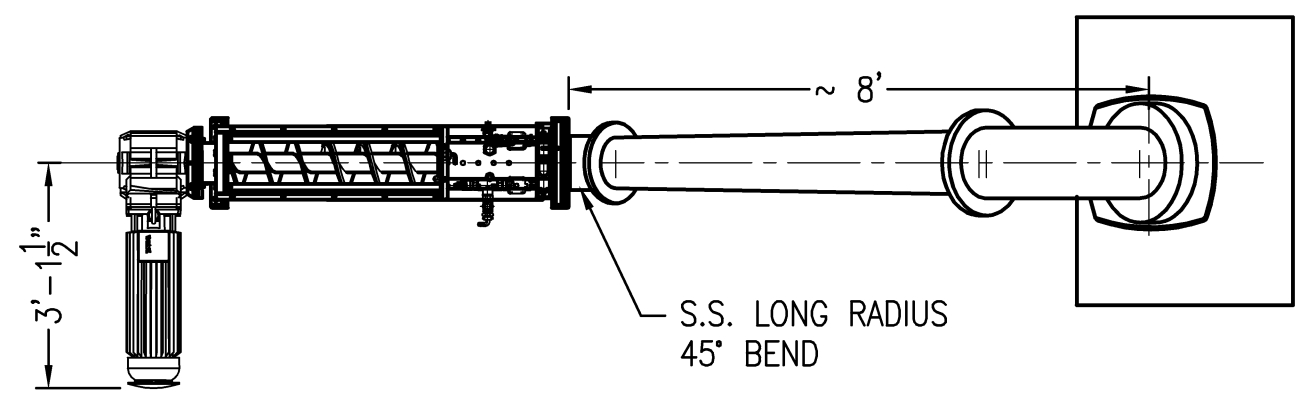

PLAN

A1 WASH PRESS DETAILS
 SCALE: 3/8" = 1'-0"

NOTE:

1. EXISTING ECUA WASH PRESS AS PROVIDED BY HUBER TECHNOLOGY.

NO.	DATE	APPR.	REVISION/ACTION TAKEN

This drawing is the property of BASKERVILLE-DONOVAN, INC. and is not to be reproduced in whole or in part. It is not to be used on any other project without the written consent of Baskerville-Donovan, Inc. and shall be returned upon request.

NOT RELEASED FOR CONSTRUCTION

PROJECT NO:	27941.05
DESIGNED BY:	CLL
DRAWN BY:	THO
CHK'D BY:	CLL
PROJ. MGR:	RWD
DATE:	SEPT. 2011
BY:	

WASH PRESS DETAILS